

«UzAuto Motors» AJ
TEXNIK TOPSHIRIQ



22TT-9036-00191 v2

2022-11-10

TEXNIK TOPSHIRIQ TT

Butlovchi qism nomi	94585727-LEVER ASSY,HTR CONTROL 94535152-CIRCLIP-FT WHEEL BRG 94583373-PLATE SET,SPRING SHACKLE INR
Texnik ko`rsatkichlari	Umumiy texnik ko'rsatkichlar, butlovchi qismga qo'yiladigan talablar va o'lchamlar butlovchi qism chizmasiga asosan (chizmalar ilova qilinadi). Hozirgi kunda "UzAuto Motors" AJ ga avtomobil butlovchi qismlar yetkazib bermaydigan yangi maxalliy korxonalar PSA(Potential Supplier Audit)dan o'tgandan keyin shartnoma tuziladi.

<p>Butlovchi qismga texnika-texnologik talablar</p>	<p style="text-align: center;">Mahsulotni qabul qilish</p> <p>Mahsulotni sifati bo'yicha qabul qilish buyurtmachining "Butlovchi qismlarni kiritish nazorati" standartiga asosan amalga oshiriladi.</p> <p>Mahsulotni miqdor va sifat bo'yicha qabul qilish buyurtmachining korxonasida ta'minotchining vakili ishtirokida amalga oshiriladi.</p> <p>Yetkazib berilgan mahsulot miqdori buyurtmachi tomonidan taqdim etilgan talabnomaga binoan, yozma yoki elektron shaklda kelishilgan shaklda berilgan hajmlarga mos kelishi lozim.</p> <p style="text-align: center;">Mahsulot sifati</p> <p>Ta'minotchi buyurtmachiga mahsulotni buyurtmachi tomonidan joriy etilgan me'yor va o'rnatilgan standart, mahsulotni sifatini, chizmalar talablari, me'yoriy xujjatlar, nazorat qilish usullari asosida yetkazib berilishiga kafolat beradi.</p> <p>Mahsulot materialini, tuzilishini yoki hujjatlarni bir tomonlama o'zgartirilishga yo'l qo'yilmaydi.</p> <p>Buyurtmachi mahsulot sifatini va ta'minotchining ekologik sertifikatini mavjudligini tekshirish huquqiga ega va zarur hollarda bu tekshirish huquqi bevosita iste'molchiga ham berilishi mumkin.</p> <p style="text-align: center;">Sifat kafolati.</p> <p>Agar mahsulot kam yetkazib berilishi va sifat nomuvofiqligi, qadoqsiz va o'ramasiz yoki talab darajasida bo'lmagan qadoqda va o'ramada kelganligi, markasiz yoki talab darajada markalanmaganligi ta'minotchi vakili ishtirokida aniqlansa, ta'minotchi 3 (uch) ish kunida ushbu kamchiliklarni bartaraf etishi va yetishmayotgan miqdorini o'z mablag'lari xisobidan to'ldirilishi lozim, shuningdek buyurtmachidan yozma xabar(pochta, faks, elektron pochta) qabul qilinganidan keyin yoki yetkazib berilgan sanadan boshlab 1 (bir) ish kuni ichida tegishli idishga qadoqlash, markalash ishlarini bajarishi kerak.</p>
<p>Butlovchi qismning ishlatilish joyi</p>	<p>Yig'uv sexida ishlatiladi</p>

Narx qismi	Tender taklifida ko`rsatilgan narxlar eng past narxdan oshmasligi kerak va keyinchalik o`zgartirilishi mumkin emas. Taqdim qilingan narxlar O`zbekiston Respublikasi milliy valyutasi so`mda va qo`shimcha qiymat solig`i (QQS) bilan ko`rsatilishi lozim.
Fotosurat	Ilovada ko'rsatilgan.
Chizmasi va umumiy talablar	Ilovada ko'rsatilgan.

<p>Qo`shimcha talablar</p>	<p style="text-align: center;">Tara va Qadoqalash</p> <p>Butlovchi qismni yetkazib berishda shakli va hajmi ta`minotchi tomonidan ishlab chiqilgan va buyurtmachi bilan kelishilgan maxsus idishlar ishlatiladi va buyurtmachi bilan kelishilgan talablarga ko`ra markalanishi lozim.</p> <p>Mahsulotni yetkazib berishda quyidagi ma`lumotlarni o`z ichiga olgan yorliq yopishtiriladi.</p> <ul style="list-style-type: none"> – avtomobil turi; – butlovchi qism nomi, raqami va soni; – ta`minotchining kodi; – yetkazib berish joyi; – idish hajmi, qadoqlash sanasi, nazorat xolati va boshqalar. <p>Butlovchi qismni yetkazib berishda shakli va hajmi ta`minotchi tomonidan ishlab chiqilgan va buyurtmachi bilan kelishilgan maxsus idishlar ishlatiladi va buyurtmachi bilan kelishilgan talablarga ko`ra markalanishi lozim.</p> <p>Mahsulotni yetkazib berishda quyidagi ma`lumotlarni o`z ichiga olgan yorliq yopishtiriladi.</p> <ul style="list-style-type: none"> – avtomobil turi; – butlovchi qism nomi, raqami va soni; – ta`minotchining kodi; – yetkazib berish joyi; – idish hajmi, qadoqlash sanasi, nazorat xolati va boshqalar.
----------------------------	--

Tasdiq

Boshqaruvchi direktor



2022-11-10 18:07

S. M. Jumaniyazov

2022-11-10 14:11

Rozilik

Bo'lim boshlig'i
Muhandislik mahsulotlari bo'limi



2022-11-09 14:25

J. S. Ismailov
2022-11-09 14:05

Boshqarma boshlig'i
*Global xarid qilish va ta'minot tizimi
boshqarmasi*



2022-11-10 14:11

U. P. Ruzibayev
2022-11-09 14:05

Bo'lim boshlig'i
Maxallillashtirish bo'limi



2022-11-09 18:24

D. K. Annaqov
2022-11-09 14:05

Bo'linma boshlig'i
HVAC, shassi va uzellar bo'linmasi



2022-11-09 14:18

O. J. Masharipov
2022-11-09 14:05

Mas'ul

2 toifali muhandis-texnolog
HVAC, shassi va uzellar bo'linmasi



2022-11-09 14:04

R. U. Sharipov
2022-11-09 14:05

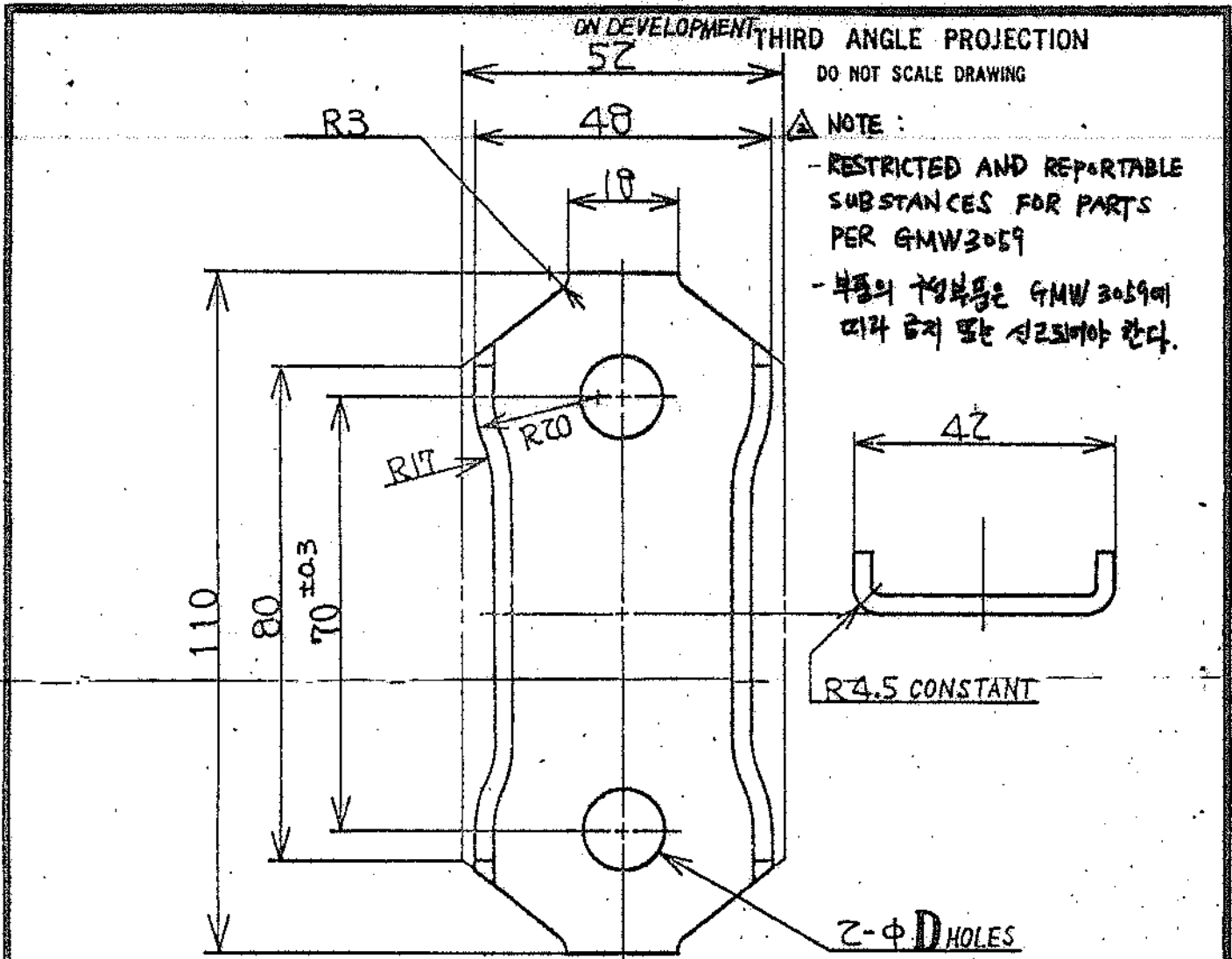

NOTE
 SURFACE FINISHING: BLACK COATING, CORROSION RESISTANCE : SALT SPRAY TEST
 120H OR MORE

	41462-79000 94583371	13 ^{+0.1} / ₀	▽▽ EQUIV.	
	41461-79000 94583370	10.5		
ITEM	PART NO.	D	REMARKS	Ⓐ

△							
△							
△	1	PCD0016D1	97.8.31	NOTE ADDED	D.W LEE	D.W LEE	
△	2	CT3-0009D	92.02.10	WAS DWG NO. 41461-19000, P/NO. CONV.	S.S. HWANG	B	
△	0	CT2-0300	92.12.30	REDWGW	J.M. JEON	李東垣	
REV	QTY	ECN. NO.	DATE	CONTENTS	RVD BY	CHKD BY	APPVD BY

PART NUMBER	41462-79000 94583371	PART NAME	" , " , OUTER PLATE, SPRING SHACKLE, INNER	GEN. TOL	DESD2101a
REF. DWG		DSND BY	J.M. JEON	CHKD BY	李東垣
MATERIAL	SPHC-P, t0.3	APPVD BY	B. GUMMOON	APPVD BY	李東垣
HEAT TREATMENT		DATE	1992. 11. 24.	WT	279.58
기종: YQT	BLK: CG 204.	SCALE	N:S	PAGE	1/1

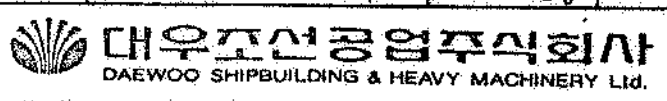

THIRD ANGLE PROJECTION
DO NOT SCALE DRAWING

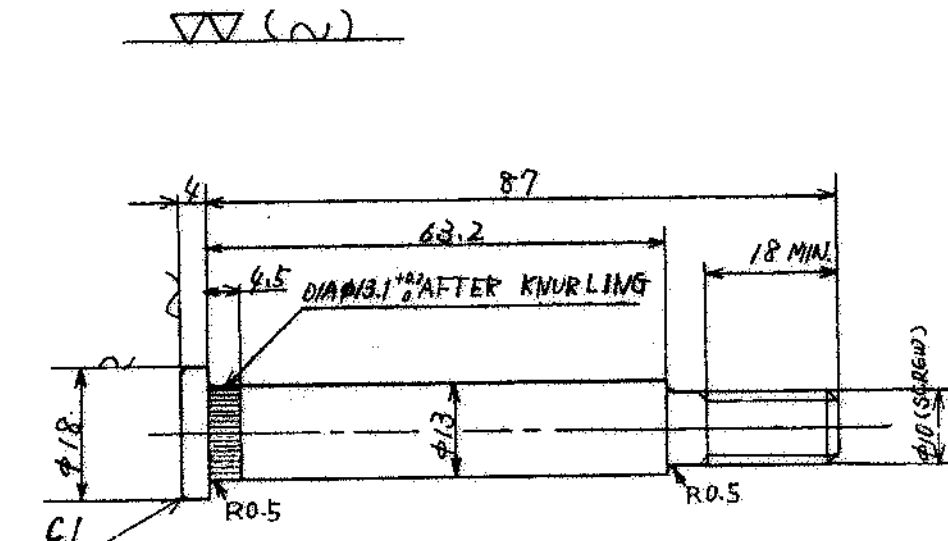

NOTES

1. SURFACE TREATMENT : AFTER ASSEMBLING PIN INTO PLATE
APPLY ZINC PHOSPHATISATION AND BLACK COATING (CATION ELECTRODEPOSITION COATING)
FILM THICKNESS : 15 μ OR MORE.
CORROSION RESISTANCE : 720 H OR MORE UNDER SALT SPRAY TEST.
2. IN CASE THAT THIS PART IS USED ONLY AS SPARE PART, SURFACE TREATMENT SHOULD BE MF2n 5-CH.

△									
△									
△									
△	1	CT3-00090	'03.02.10	WAS DWG NO. 41463-82000.		S.S. HWANG			
△	0	CT2-0300	'92.12.30	REDWG		J.M. JEON	李東垣		
REV	QTY	ECN. NO.	DATE	CONTENTS		RVD' BY	CHKD BY	APPVD BY	
PART NUMBER				PART NAME				GEN. TOL	
△ 94583372 41463-82000				PIN, SPRING SHACKLE				DESD2101a	
REF. DWG		SURFACE FINISHING		DSND BY	CHKD BY	APPVD BY	APPVD BY		
S40C		SEE NOTES		J.M. JEON	李東垣	B. SUMOON	황재		
HEAT TREATMENT		SCALE		DATE		WT:		SZ:	
QUENCHING & TEMPERING (HRC 20~28)		N:5		1992. 11. 24.		/		4	
기종: Y7T		BLK: CG 204		PAGE					
		1/1							
				대우조선공업주식회사 DAEWOO SHIPBUILDING & HEAVY MACHINERY Ltd.					