

«UzAuto Motors» AJ
TEXNIK TOPSHIRIQ



22TT-9029-00012

2022-02-07

TEXNIK TOPSHIRIQ TT

Butlovchi qism nomi	-94581658-DUCT-A/CL ADAP -96915442-TANK ASSY-WATER RESERVOIR -96915415-RESONATOR SET,AIR CLEANER
Texnik ko`rsatkichlari	Material -94581658-DUCT-A/CL ADAP PP-Bz(BLACK) -96915442-TANK ASSY-WATER RESERVOIR EPDM, PP, PP -96915415-RESONATOR SET,AIR CLEANER PE-B1(BLACK)

Butlovchi
qismga
texnika-
texnologik
talablar

Mahsulotni qabul qilish

Mahsulotni sifati bo'yicha qabul qilish buyurtmachining "Butlovchi qismlarni kiritish nazorati" standartiga asosan amalga oshiriladi.

Mahsulotni miqdor va sifat bo'yicha qabul qilish buyurtmachining korxonasida ta'minotchining vakili ishtirokida amalga oshiriladi.

Yetkazib berilgan mahsulot miqdori buyurtmachi tomonidan taqdim etilgan talabnomaga binoan, yozma yoki elektron shaklda kelishilgan shaklda berilgan hajmlarga mos kelishi lozim.

Mahsulot sifati

Ta'minotchi buyurtmachiga mahsulotni buyurtmachi tomonidan joriy etilgan me'yor va o'rnatilgan standart, mahsulotni sifatini, chizmalar talablari, me'yoriy xujjatlar, nazorat qilish usullari asosida yetkazib berilishiga kafolat beradi.

Mahsulot materialini, tuzilishini yoki hujjatlarni bir tomonlama o'zgartirilishga yo'l qo'yilmaydi.

Buyurtmachi mahsulot sifatini va ta'minotchining ekologik sertifikatini mavjudligini tekshirish huquqiga ega va zarur hollarda bu tekshirish huquqi bevosita iste'molchiga ham berilishi mumkin.

Sifat kafolati.

Agar mahsulot kam yetkazib berilishi va sifat nomuvofiqligi, qadoqsiz va o'ramasiz yoki talab darajasida bo'lmagan qadoqda va o'ramada kelganligi, markasiz yoki talab darajada markalanmaganligi ta'minotchi vakili ishtirokida aniqlansa, ta'minotchi 3 (uch) ish kunida ushbu kamchiliklarni bartaraf etishi va yetishmayotgan miqdorini o'z mablag'lari xisobidan to'ldirilishi lozim, shuningdek buyurtmachidan yozma xabar(pochta, faks, elektron pochta) qabul qilinganidan keyin yoki yetkazib berilgan sanadan boshlab 1 (bir) ish kuni ichida tegishli idishga qadoqlash, markalash ishlarini bajarishi kerak.

Butlovchi qismning ishlatilish joyi	Yig'uv tsexida ishlatiladi
Narx qismi	Tender taklifida ko'rsatilgan narxlar eng past narxdan oshmasligi kerak va keyinchalik o'zgartirilishi mumkin emas. Taqdim qilingan narxlar O'zbekiston Respublikasi milliy valyutasi so'mda va qo'shimcha qiymat solig'i (QQS) bilan ko'rsatilishi lozim.
Fotosurat	Ilovada ko'rsatilgan.
Chizmasi va umumiy talablar	Ilovada ko'rsatilgan.

<p>Qo`shimcha talablar</p>	<p style="text-align: center;">Tara va Qadoqalash</p> <p>Butlovchi qismni yetkazib berishda shakli va hajmi ta`minotchi tomonidan ishlab chiqilgan va buyurtmachi bilan kelishilgan maxsus idishlar ishlatiladi va buyurtmachi bilan kelishilgan talablarga ko`ra markalanishi lozim.</p> <p>Mahsulotni yetkazib berishda quyidagi ma`lumotlarni o`z ichiga olgan yorliq yopishtiriladi.</p> <ul style="list-style-type: none"> – avtomobil turi; – butlovchi qism nomi, raqami va soni; – ta`minotchining kodi; – yetkazib berish joyi; – idish hajmi, qadoqlash sanasi, nazorat xolati va boshqalar. <p>Butlovchi qismni yetkazib berishda shakli va hajmi ta`minotchi tomonidan ishlab chiqilgan va buyurtmachi bilan kelishilgan maxsus idishlar ishlatiladi va buyurtmachi bilan kelishilgan talablarga ko`ra markalanishi lozim.</p> <p>Mahsulotni yetkazib berishda quyidagi ma`lumotlarni o`z ichiga olgan yorliq yopishtiriladi.</p> <ul style="list-style-type: none"> – avtomobil turi; – butlovchi qism nomi, raqami va soni; – ta`minotchining kodi; – yetkazib berish joyi; – idish hajmi, qadoqlash sanasi, nazorat xolati va boshqalar.
----------------------------	--

Tasdiq

Boshqaruvchi direktor



2022-02-07 11:53

**S. M.
Jumaniyazov**
2022-02-07 11:27

Bo'lim ichida rozilik

Boshqarma boshlig'i

*Global xarid qilish va ta'minot tizimi
boshqarmasi*



2022-02-07 11:27

U. P. Ruzibayev

2022-02-07 10:26

Bo'lim boshlig'i

Maxallillashtirish bo'limi



2022-02-07 11:11

D. K. Annaqov

2022-02-07 10:26

Bo'linma boshlig'i

HVAC, shassi va uzellar bo'linmasi



2022-02-07 11:06

E. I. Qilichov

2022-02-07 10:26

Mas'ul

Muhandis-texnolog

HVAC, shassi va uzellar bo'linmasi



2022-02-07 10:19

B. U. Raximov

2022-02-07 10:26

THIRD ANGLE PROJECTION
DO NOT SCALE DRAWING

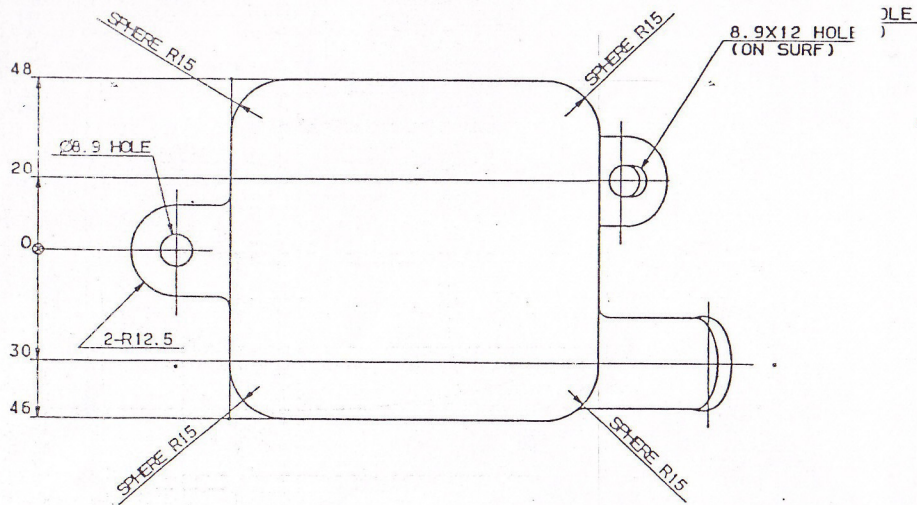
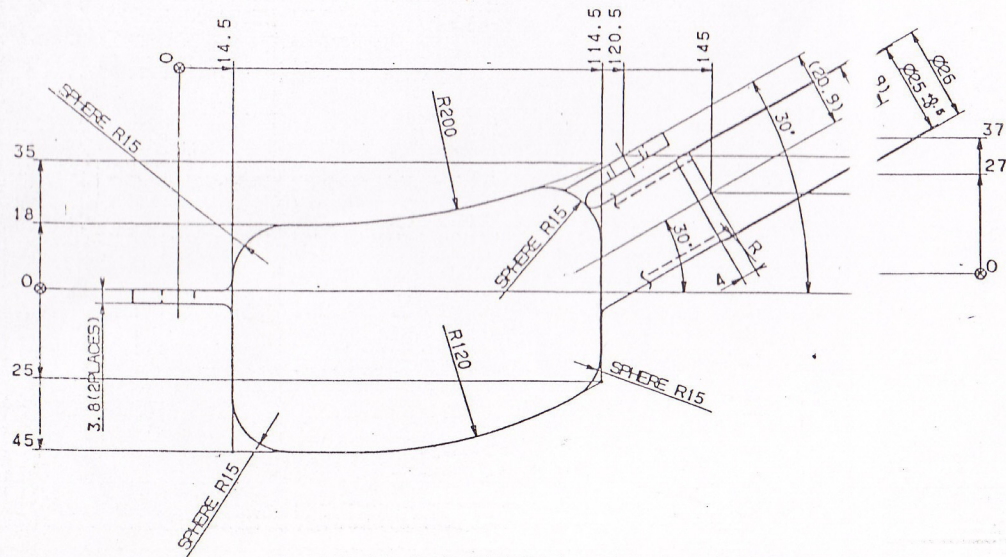

NOTE

1. UNSPECIFIED CORNER R : R3.
2. BASIC WALL THICKNESS : 2.0.
(MIN. WALL THICKNESS : MIN. 1.3).
3. THIS D.W.G. IS ALL DIMENSIONED ON OUTSIDE.
4. BE FREE FROM BURRS.
5. MATERIAL QUALITY SHOULD MEET "DES N 3213".

주 기

1. 지시하지 않은 모서리 R : R3.
2. 기본 두께 : 2.0 (최소 두께 : 1.3 이상).
3. 본 도면은 판외 치수로 한다.
4. BURR 없을 것.
5. 재질, 품질은 DES N 3213을 만족 할 것.



REV/ QTY	ECON NO	DATE	CONTENTS
1	ET3-0014	2003. 7. 25	GAH P/NO CONV.

REDESIGNED ACC. TO
ET3-0014

PART NUMBER 94 581 607 43761-80000		PART NAME RESONATOR, AIR CLNR		GEN. TOL DESD2101a	
REF. DWG	SURFACE FINISHING	DSND BY	CHKD BY	APPVD BY	APPVD BY
MATERIAL PE-BI(BLACK)		기동원	양재	최태원	92.12.14
HEAT TREATMENT	SCALE	DATE	WT.	SZ.	
	1/1	1992. 11. 14.	12.4g	A2	
DAEWOO SHIPBUILDING & HEAVY MACHINERY LTD.					

ITEM	PART NO.	P/
------	----------	----

PART NAME	QTY	MATERIAL	REMARKS
기동: Y11		BLK: C1110	

THIRD ANGLE PROJECTION
DO NOT SCALE DRAWING

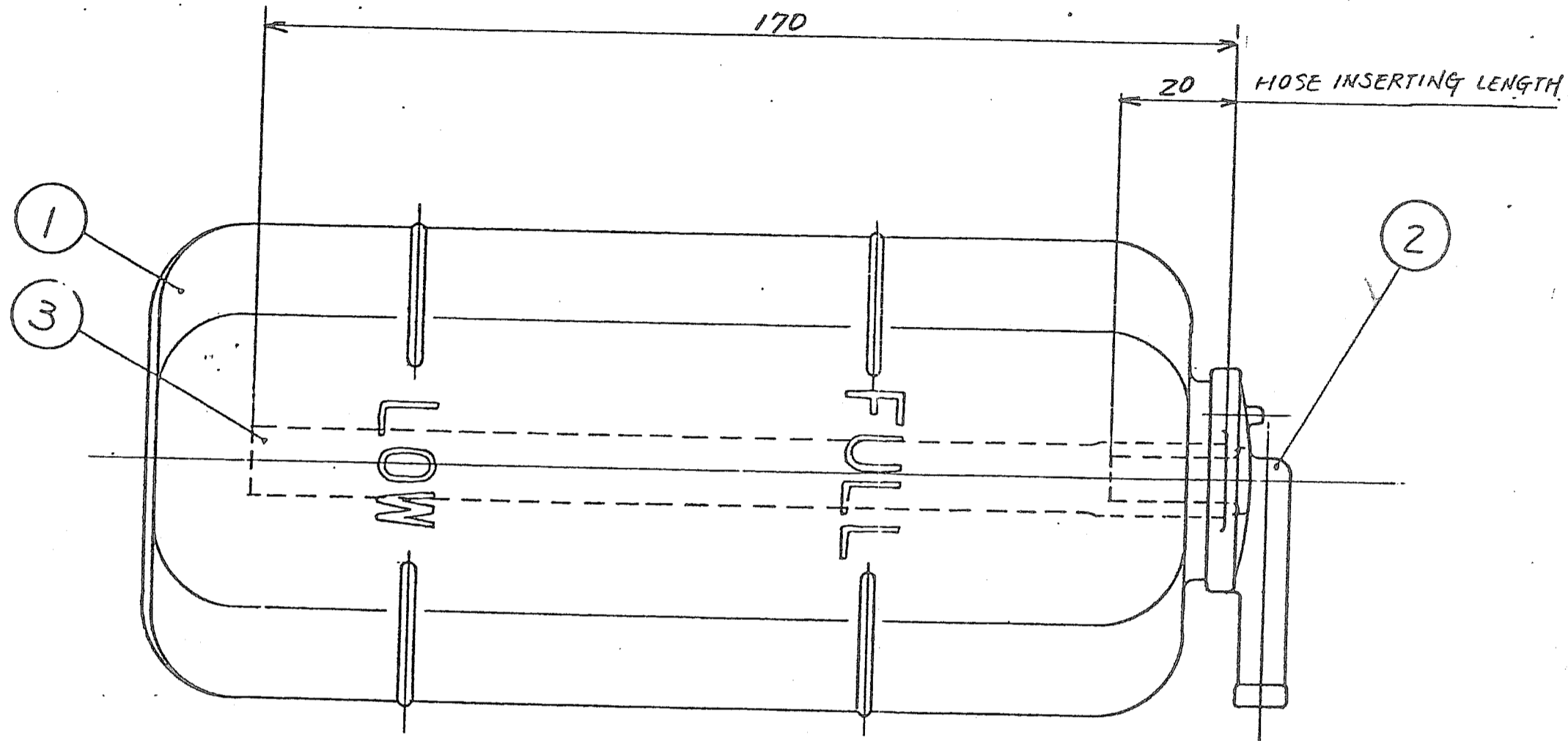

NOTE
 - RESTRICTED AND REPORTABLE SUBSTANCES
 FOR PARTS PER GMW3059.
 - 부품의 구성 성분은 GMW 3059에 따라
 금지 또는 신고되어야 한다.

ITEM	PART NO.	PART NAME	QTY	MATERIAL	REMARKS
3	09352-70111-170	HOSE, WATER RSVR TANK	1	EPDM	94581967
2	17932-78100	CAP, WATER RSVR TANK	1	PP	94581967
1	17931-72000 1Δ	TANK, WATER RESERVE	1	PP	94581967

PART NUMBER 94581967 17930-78100		PART NAME TANK ASSY. WATER RESERVE		GEN. TOL DESD2101a	
REF. DWG	MATERIAL SEE NOTE	SURFACE FINISHING	DSND BY 1992.10.28	CHKD BY 11.25	APPVD BY 11.25
HEAT TREATMENT	SCALE 1:1	PAGE 1/1	DATE 1992.10.28	WT.	SZ: A3
대우조선공업주식회사 DAEWOO SHIPBUILDING & HEAVY MACHINERY Ltd.					

REDESIGNED ACC. TO
ET3-0014

REV.	QTY	ECN NO.	DATE	CONTENTS	RVD BY	CHKD BY	APPVD BY
1		ET3-0154	94.11.30	TANK 재검정	신우용	신우용	C.S.108
2		ET3-0020B 03.2.15		GM PART NO. COMU.	신우용	신우용	
3		ET3-0035D 02.8.25		ADDED NOTE	신우용	신우용	

DWS(R)90-022
A3(420 X 297mm) FILM

1992. 9. 1.

REV.	QTY	ECN NO.	DATE	CONTENTS	RVD BY	CHKD BY	APPVD BY
1		GS57E 30093		DRAWING RELEASE			
2		GD07D 23093		MPL CORRECTION			
3		GS57E 20093		DRAWING RELEASE			

PART NUMBER 96 915 442		PART NAME TANK ASSY, WATER RESERVE		GEN. TOL EDS-A-1101	
REF. DWG: 96915442	MATERIAL	SURFACE FINISHING	DSND BY	CHKD BY	APPVD BY
HEAT TREATMENT	SCALE N : S	PAGE 1/1	DATE: 2013	WT:	SZ: A1
GMUZBEKISTAN					

ITEM	PART NO.	PART NAME	QTY	MATERIAL	REMARKS