

«UzAuto Motors» AJ
TEXNIK TOPSHIRIQ



22TT-9029-00073

2022-04-25

TEXNIK TOPSHIRIQ TT

Butlovchi qism nomi	94584271/4165 - REINF,FRONT SUSPENSION, R/L butlovchi qismi
Texnik ko`rsatkichlari	Material: SPHC or SPCC t=1.4
Butlovchi qismga texnika-texnologik talablar	<p style="text-align: center;">Mahsulotni qabul qilish</p> <p>Masulotni sifati bo`yicha qabul qilish buyurtmachining “Butlovchi qismlarni kiritish nazorati” standartiga asosan amalga oshiriladi.</p> <p>Mahsulotni miqdor va sifat bo`yicha qabul qilish buyurtmachining korxonasida ta`minotchining vakili ishtirokida amalga oshiriladi.</p> <p>Yetkazib berilgan mahsulot miqdori buyurtmachi tomonidan taqdim etilgan talabnomaga binoan, yozma yoki elektron shaklda kelishilgan shaklda berilgan hajmlarga mos kelishi lozim.</p> <p style="text-align: center;">Mahsulot sifati</p> <p>Ta`minotchi buyurtmachiga mahsulotni buyurtmachi tomonidan joriy etilgan me`yor va o`rnatilgan standart, mahsulotni sifatini, chizmalar talablari, me`yoriy xujjatlar, nazorat qilish usullari asosida yetkazib berilishiga kafolat beradi.</p> <p>Mahsulot materialini, tuzilishini yoki hujjatlarni bir tomonlama o`zgartirilishga yo`l qo`yilmaydi.</p> <p>Buyurtmachi mahsulot sifatini va ta`minotchining ekologik sertifikatini mavjudligini tekshirish huquqiga ega va zarur hollarda bu tekshirish huquqi bevosita iste`molchiga ham berilishi mumkin.</p> <p style="text-align: center;">Sifat kafolati.</p>

	<p>Agar mahsulot kam yetkazib berilishi va sifat nomuvofiqligi, qadoqsiz va o`ramasiz yoki talab darajasida bo`lmagan qadoqda va o`ramada kelganligi, markasiz yoki talab darajada markalanmaganligi ta`minotchi vakili ishtirokida aniqlansa, ta`minotchi 3 (uch) ish kunida ushbu kamchiliklarni bartaraf etishi va yetishmayotgan miqdorini o`z mablag`lari xisobidan to`ldirilishi lozim, shuningdek buyurtmachidan yozma xabar(pochta, faks, electron pochta) qabul qilinganidan keyin yoki yetkazib berilgan sanadan boshlab 1 (bir) ish kuni ichida tegishli idishga qadoqlash, markalash ishlarini bajarishi kerak.</p>
Butlovchi qismning ishlatilish joyi	Presslash sexida ishlatiladi
Narx qismi	Eng yaxshi taklifni tanlash konkursida ko`rsatilgan narxlar eng past narxdan oshmasligi kerak va keyinchalik o`zgartirilishi mumkin emas. Taqdim qilingan narxlar O`zbekiston Respublikasi milliy valyutasi so`mda va qo`shimcha qiymat solig`i (QQS) bilan ko`rsatilishi lozim.
Chizmasi va umumiy talablar	Ilovada ko'rsatilgan.

<p>Qo`shimcha talablar</p>	<p style="text-align: center;">Tara va Qadoqalash</p> <p>Butlovchi qismni yetkazib berishda shakli va hajmi ta`minotchi tomonidan ishlab chiqilgan va buyurtmachi bilan kelishilgan maxsus idishlar ishlatiladi va buyurtmachi bilan kelishilgan talablarga ko`ra markalanishi lozim.</p> <p>Mahsulotni yetkazib berishda quyidagi ma`lumotlarni o`z ichiga olgan yorliq yopishtiriladi.</p> <ul style="list-style-type: none"> – avtomobil turi; – butlovchi qism nomi, raqami va soni; – ta`minotchining kodi; – yetkazib berish joyi; – idish hajmi, qadoqlash sanasi, nazorat xolati va boshqalar. <p>Butlovchi qismni yetkazib berishda shakli va hajmi ta`minotchi tomonidan ishlab chiqilgan va buyurtmachi bilan kelishilgan maxsus idishlar ishlatiladi va buyurtmachi bilan kelishilgan talablarga ko`ra markalanishi lozim.</p> <p>Mahsulotni yetkazib berishda quyidagi ma`lumotlarni o`z ichiga olgan yorliq yopishtiriladi.</p> <ul style="list-style-type: none"> – avtomobil turi; – butlovchi qism nomi, raqami va soni; – ta`minotchining kodi; – yetkazib berish joyi; – idish hajmi, qadoqlash sanasi, nazorat xolati va boshqalar.
----------------------------	--

Tasdiq

Boshqaruvchi direktor



2022-04-25 15:35

**S. M.
Jumaniyazov**
2022-04-25 11:05

Boshqarma boshlig'i

*Global xarid qilish va ta'minot tizimi
boshqarmasi*



2022-04-25 11:05

U. P. Ruzibayev

2022-04-22 16:00

Bo'lim boshlig'i

Maxallillashtirish bo'limi



2022-04-25 10:53

D. K. Annaqov

2022-04-22 16:00

Bo'linma boshlig'i

*Interior, Exterior va kuzov qismlari
bo'linmasi*



2022-04-22 16:00

G. A. Saidov

2022-04-22 15:36

Mas'ul

Muhandis-texnolog

*Interior, Exterior va kuzov qismlari
bo'linmasi*



2022-04-22 14:21

B. R.

Qutlimuratov

2022-04-22 15:36

THIRD ANGLE PROJECTION
DO NOT SCALE DRAWING

NOTE

- RESTRICTED AND REPORTABLE SUBSTANCES FOR PARTS PER GMW3059.
- 부품의 구성 성분은 GMW 3059에 따라 금지 또는 신고되어야 한다.

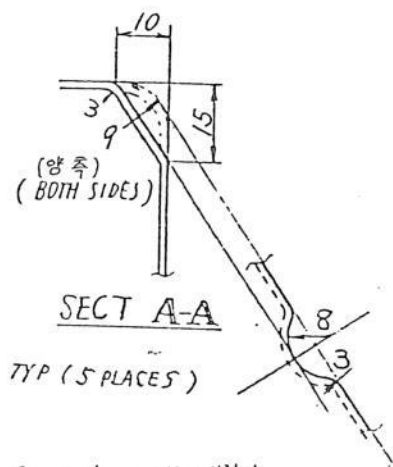
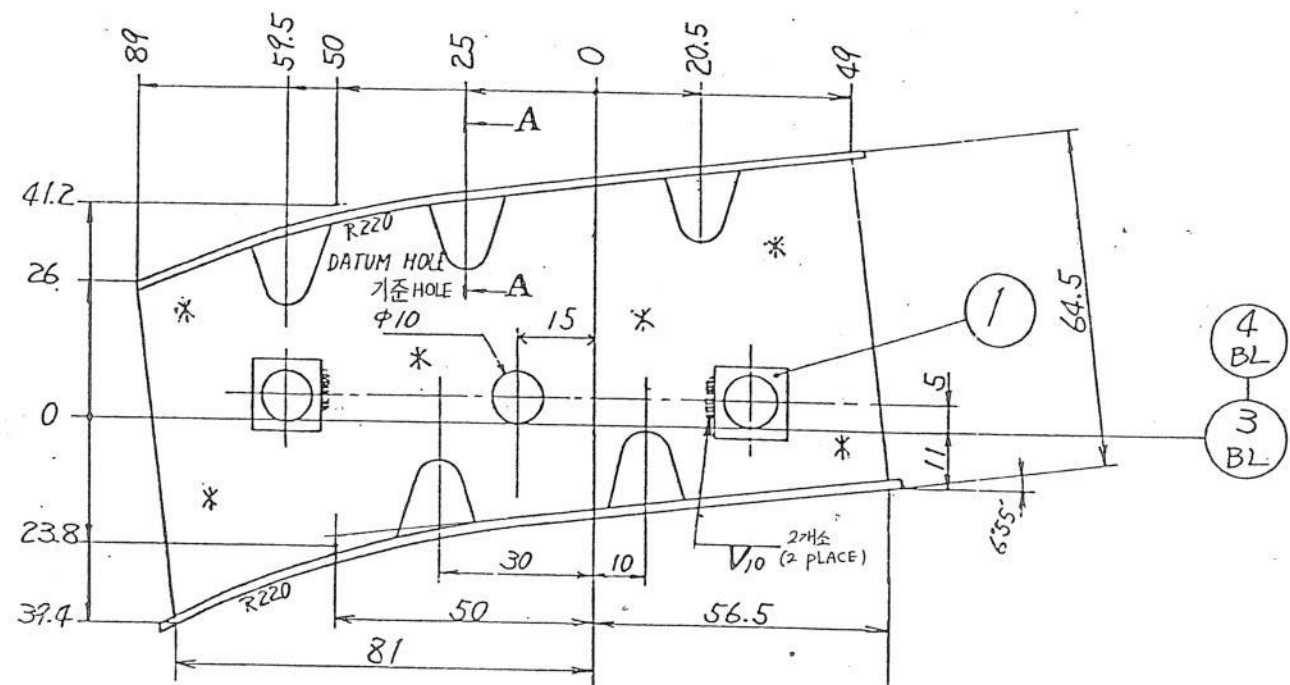

- 주기
1. 본도는 RH 이어, LH는 대칭임
 2. 투입재료는 강방형이다.
 3. 59111A8 과 MATCH 함.

NOTES

1. RH PART SHOWN, LH SYMM.
2. STOCK SHAPE: RECTANGLE.
3. MATCH WITH 59111A8

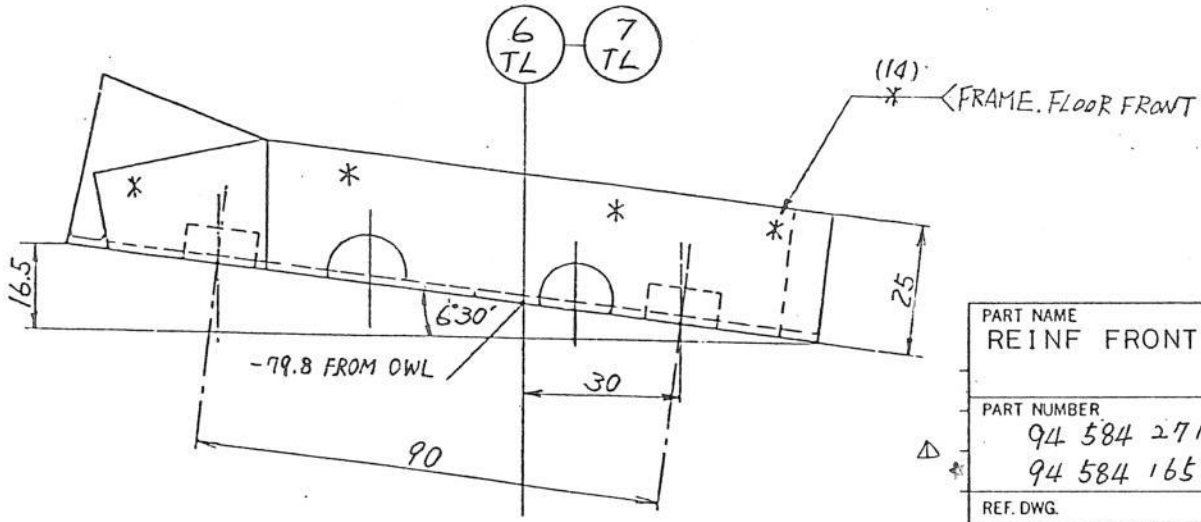

PART NAME REINF FRONT SUSPENSION, R/L		△							
PART NUMBER 94 584 271 -L 94 584 165 -R		△	1	PCB002501	ADDED NOTE	31.01.07	김명상		
REF. DWG.		△	4	BT3-0001D	Pls. use this ref. in A3, 100, 0231E-11.02	103.2.10	김명상		
MATERIAL SPHC OR SPCC t1.4		△			RE-DRAW '94	92.12.31	김명상		
HEAT TREATMENT		REV.	QTY	ECN. NO.	CONTENTS	DATE	RVD'BY		
SURFACE FINISHING		SCALE		PAGE					
DWG. BY 김명상		CHECKED BY 원경석		APPRD BY 김명상		APPRD BY			
기종: Y7T 11		BLK: CL 150		WT: 175g		SZ: A 3			

1	94 515 081	NUT FRONT SUSPENSION	2			
ITEM	PART NO.	PART NAME	Q'TY	MATERIAL	REMARKS	

