

«UzAuto Motors» AJ
TEXNIK TOPSHIRIQ



22TT-9029-00086

2022-05-19

TEXNIK TOPSHIRIQ TT

Butlovchi qism nomi	-94585647-HOUSING ASM-HDLP OPG, L -94585636-HOUSING ASM-HDLP OPG, L
Texnik ko`rsatkichlari	Material -94585647-HOUSING ASM-HDLP OPG, L PP -94585636-HOUSING ASM-HDLP OPG, L PP

<p>Butlovchi qismga texnika-texnologik talablar</p>	<p style="text-align: center;">Mahsulotni qabul qilish</p> <p>Masulotni sifati bo`yicha qabul qilish buyurtmachining “Butlovchi qismlarni kiritish nazorati” standartiga asosan amalga oshiriladi.</p> <p>Mahsulotni miqdor va sifat bo`yicha qabul qilish buyurtmachining korxonasida ta`minotchining vakili ishtirokida amalga oshiriladi.</p> <p>Yetkazib berilgan mahsulot miqdori buyurtmachi tomonidan taqdim etilgan talabnomaga binoan, yozma yoki elektron shaklda kelishilgan shaklda berilgan hajmlarga mos kelishi lozim.</p> <p style="text-align: center;">Mahsulot sifati</p> <p>Ta`minotchi buyurtmachiga mahsulotni buyurtmachi tomonidan joriy etilgan me`yor va o`rnatilgan standart, mahsulotni sifatini, chizmalar talablari, me`yoriy xujjatlar, nazorat qilish usullari asosida yetkazib berilishiga kafolat beradi.</p> <p>Mahsulot materialini, tuzilishini yoki hujjatlarni bir tomonlama o`zgartirilishga yo`l qo`yilmaydi.</p> <p>Buyurtmachi mahsulot sifatini va ta`minotchining ekologik sertifikatini mavjudligini tekshirish huquqiga ega va zarur hollarda bu tekshirish huquqi bevosita iste`molchiga ham berilishi mumkin.</p> <p style="text-align: center;">Sifat kafolati.</p> <p>Agar mahsulot kam yetkazib berilishi va sifat nomuvofiqligi, qadoqsiz va o`ramasiz yoki talab darajasida bo`lmagan qadoqda va o`ramada kelganligi, markasiz yoki talab darajada markalanmaganligi ta`minotchi vakili ishtirokida aniqlansa, ta`minotchi 3 (uch) ish kunida ushbu kamchiliklarni bartaraf etishi va yetishmayotgan miqdorini o`z mablag`lari xisobidan to`ldirilishi lozim, shuningdek buyurtmachidan yozma xabar(pochta, faks, electron pochta) qabul qilinganidan keyin yoki yetkazib berilgan sanadan boshlab 1 (bir) ish kuni ichida tegishli idishga qadoqlash, markalash ishlarini bajarishi kerak.</p>
<p>Butlovchi qismning ishlatilish joyi</p>	<p>Yig'uv sexida ishlatiladi</p>

Narx qismi	Tender taklifida ko`rsatilgan narxlar eng past narxdan oshmasligi kerak va keyinchalik o`zgartirilishi mumkin emas. Taqdim qilingan narxlar O`zbekiston Respublikasi milliy valyutasi so`mda va qo`shimcha qiymat solig`i (QQS) bilan ko`rsatilishi lozim.
Fotosurat	Ilovada ko'rsatilgan.
Chizmasi va umumiy talablar	Ilovada ko'rsatilgan.
Qo`shimcha talablar	<p style="text-align: center;">Tara va Qadoqalash</p> <p>Butlovchi qismni yetkazib berishda shakli va hajmi ta`minotchi tomonidan ishlab chiqilgan va buyurtmachi bilan kelishilgan maxsus idishlar ishlatiladi va buyurtmachi bilan kelishilgan talablarga ko`ra markalanishi lozim.</p> <p>Mahsulotni yetkazib berishda quyidagi ma`lumotlarni o`z ichiga olgan yorliq yopishtiriladi.</p> <ul style="list-style-type: none"> – avtomobil turi; – butlovchi qism nomi, raqami va soni; – ta`minotchining kodi; – yetkazib berish joyi; – idish hajmi, qadoqlash sanasi, nazorat xolati va boshqalar.

Tasdiq

Boshqaruvchi direktor



2022-05-19 08:51

**S. M.
Jumaniyazov**
2022-05-19 08:16

Bo'lim ichida rozilik

Boshqarma boshlig'i

*Global xarid qilish va ta'minot tizimi
boshqarmasi*



2022-05-19 08:16

U. P. Ruzibayev
2022-05-18 08:41

Bo'lim boshlig'i

Maxallillashtirish bo'limi



2022-05-18 17:26

D. K. Annaqov
2022-05-18 08:41

Bo'linma boshlig'i
HVAC, shassi va uzellar bo'linmasi



2022-05-18 09:42

E. I. Qilichov
2022-05-18 08:41

Mas'ul

Muhandis-texnolog
HVAC, shassi va uzellar bo'linmasi



2022-05-18 08:27

B. U. Raximov
2022-05-18 08:41

Texnik topshiriq (TT)

Butlovchi qism nomi	-94585647-HOUSING ASM-HDLP OPG, L -94585636-HOUSING ASM-HDLP OPG, L
Texnik ko`rsatkichlari	Material -94585647-HOUSING ASM-HDLP OPG, L PP -94585636-HOUSING ASM-HDLP OPG, L PP
Butlovchi qismga texnika-texnologik talablar	<p style="text-align: center;">Mahsulotni qabul qilish</p> <p>Masulotni sifati bo'yicha qabul qilish buyurtmachining "Butlovchi qismlarni kiritish nazorati" standartiga asosan amalga oshiriladi.</p> <p>Mahsulotni miqdor va sifat bo'yicha qabul qilish buyurtmachining korxonasida ta'minotchining vakili ishtirokida amalga oshiriladi.</p> <p>Yetkazib berilgan mahsulot miqdori buyurtmachi tomonidan taqdim etilgan talabnomaga binoan, yozma yoki elektron shaklda kelishilgan shaklda berilgan hajmlarga mos kelishi lozim.</p> <p style="text-align: center;">Mahsulot sifati</p> <p>Ta'minotchi buyurtmachiga mahsulotni buyurtmachi tomonidan joriy etilgan me'yor va o'rnatilgan standart, mahsulotni sifatini, chizmalar talablari, me'yoriy xujjatlar, nazorat qilish usullari asosida yetkazib berilishiga kafolat beradi.</p> <p>Mahsulot materialini, tuzilishini yoki hujjatlarni bir tomonlama o'zgartirishga yo'l qo'yilmaydi.</p> <p>Buyurtmachi mahsulot sifatini va ta'minotchining ekologik sertifikatini mavjudligini tekshirish huquqiga ega va zarur hollarda bu tekshirish huquqi bevosita iste'molchiga ham berilishi mumkin.</p> <p style="text-align: center;">Sifat kafolati.</p> <p>Agar mahsulot kam yetkazib berilishi va sifat nomuvofiqligi, qadoqsiz va o'ramasiz yoki talab darajasida bo'lmagan qadoqda va o'ramada kelganligi, markasiz yoki talab darajada markalanmaganligi ta'minotchi vakili ishtirokida aniqlansa, ta'minotchi 3 (uch) ish kunida ushbu kamchiliklarni bartaraf etishi va yetishmayotgan miqdorini o'z mablag'lari xisobidan to'ldirilishi lozim, shuningdek buyurtmachidan yozma xabar(pochta, faks, elektron pochta) qabul qilinganidan keyin yoki yetkazib berilgan sanadan boshlab 1 (bir) ish kuni ichida tegishli idishga qadoqlash, markalash ishlarini bajarishi kerak.</p>
Butlovchi qismning ishlatilish joyi	Yig'uv sexida ishlatiladi
Narx qismi	<p>Tender taklifida ko`rsatilgan narxlar eng past narxdan oshmasligi kerak va keyinchalik o'zgartirilishi mumkin emas.</p> <p>Taqdim qilingan narxlar O'zbekiston Respublikasi milliy valyutasi so`mda va qo`shimcha qiymat solig'i (QQS) bilan ko`rsatilishi lozim.</p>
Fotosurat	<div style="display: flex; justify-content: space-around; align-items: center;"> <div style="text-align: center;">  <p style="color: blue; font-weight: bold;">품명 및 내 각인 획</p> <p>94585647</p> </div> <div style="text-align: center;">  <p style="color: blue; font-weight: bold;">품명 및 내 각인 획</p> <p>94585636</p> </div> </div>

Chizmasi va umumiy talablar	Ilova qilinadi
Qo`shimcha talablar	<p style="text-align: center;">Tara va qadoqlash</p> <p>Butlovchi qismni yetkazib berishda shakli va hajmi ta`minotchi tomonidan ishlab chiqilgan va buyurtmachi bilan kelishilgan maxsus idishlar ishlatiladi va buyurtmachi bilan kelishilgan talablarga ko`ra markalanishi lozim.</p> <p>Mahsulotni yetkazib berishda quyidagi ma`lumotlarni o`z ichiga olgan yorliq yopishtiriladi.</p> <ul style="list-style-type: none">– avtomobil turi;– butlovchi qism nomi, raqami va soni;– ta`minotchining kodi;– yetkazib berish joyi;– idish hajmi, qadoqlash sanasi, nazorat xolati va boshqalar.

THIRD ANGLE PROJECTION
DO NOT SCALE DRAWING

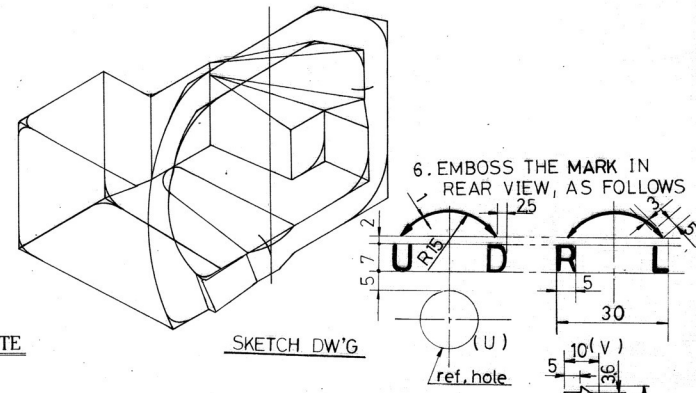
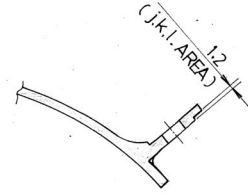
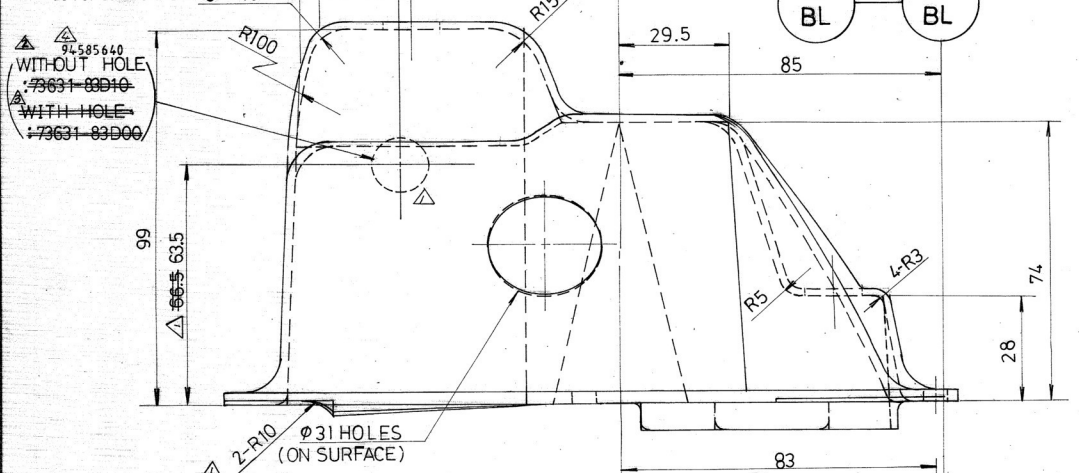

SECT. A-A

SKETCH DW'G

NOTE

1. UNSPECIFIED WALL THICKNESS: 2.0t
2. BETWEEN *1 AND *2, *3 RADIUS SHALL CONTINUOUSLY VARY FROM R100 TO R400.
3. GRAIN: TANAZAWA HOKKOSA. TH-108.
4. MATERIAL: LUCKY GP 3202 EQUIVALENT.
5. MARK MATERIAL SYMBOLS AS FOLLOW IN (ALL-AROUND) ACCORDANCE WITH DES N3220. SAE PP > PP-GF20 <
6. RESTRICTED AND REPORTABLE SUBSTANCES FOR PARTS PER 6MW 3059.

ARROW MARK

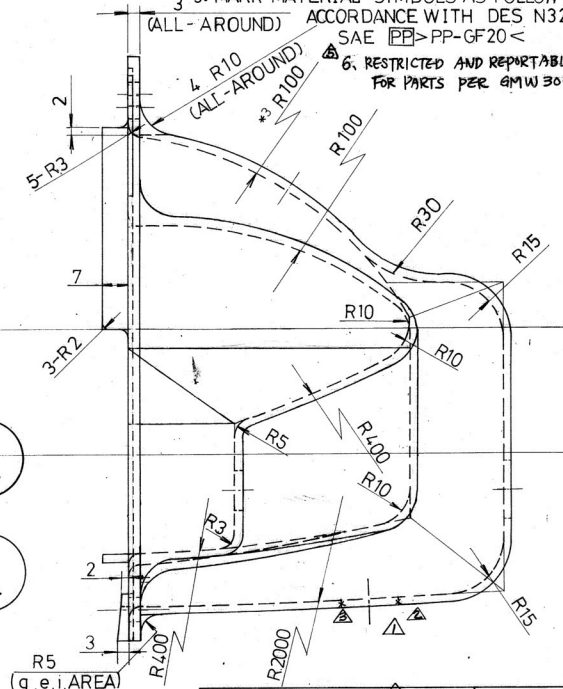
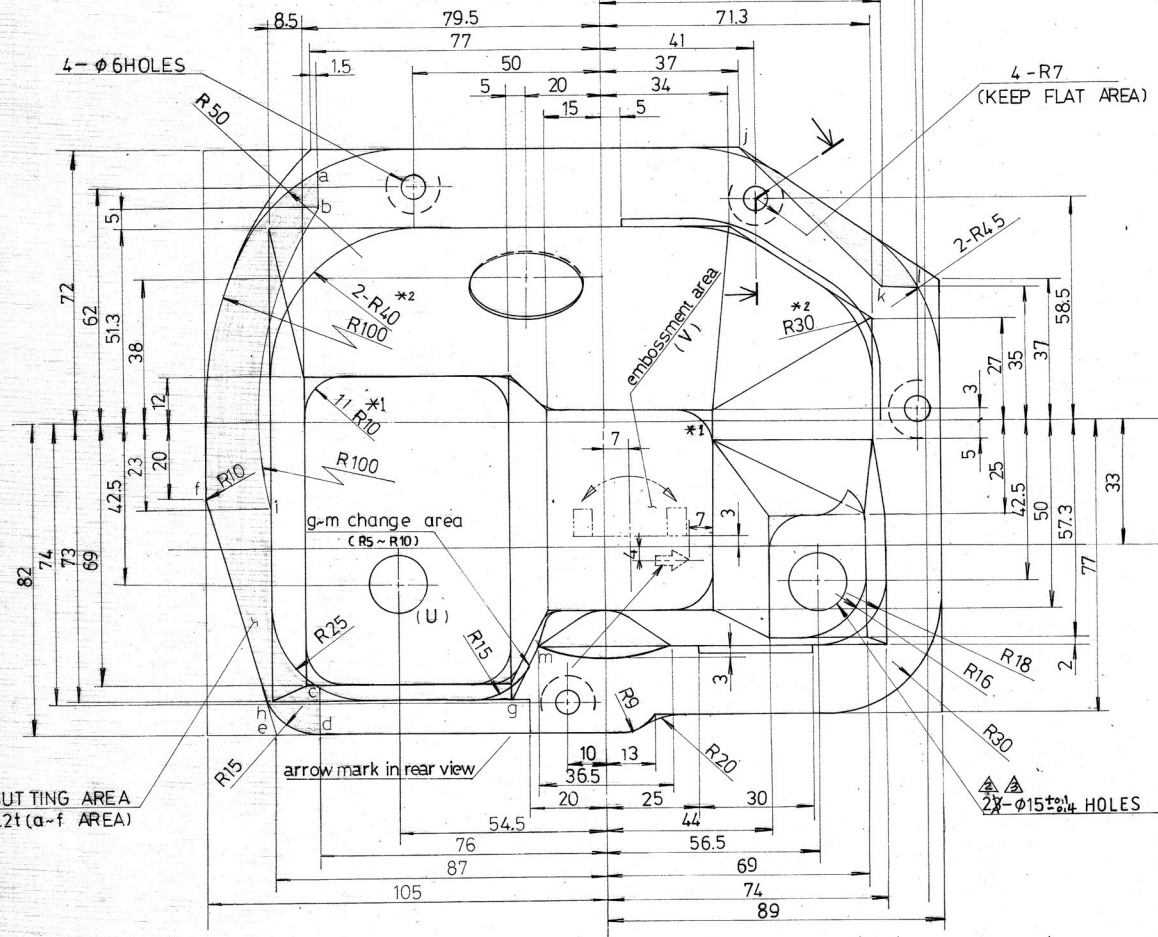

CUTTING AREA
1.2t (a-f AREA)

PART NUMBER 73631-83D10 94585640 73631-83D00		PART NAME BOX, HEADLAMP HSG, RH		GEN. TOL. DESD2101a	
REF. DWG	MATERIAL	SURFACE FINISHING	DATE	WT	SZ
	PP		19 95 . 2 . 21	102g	2
HEAT TREATMENT	SCALE	PAGE	DAEWOO HEAVY INDUSTRIES LTD.		
	1 : 1	1 / 1	DAEWOO HEAVY INDUSTRIES LTD.		

ITEM	PART NO.	PART NAME	QTY	MATERIAL	REMARKS	기호	YTT	BLK	CS125
------	----------	-----------	-----	----------	---------	----	-----	-----	-------

REDESIGNED ACC. TO					
1	94585640	94585640	94585640	94585640	94585640
2	73631-83D10	73631-83D10	73631-83D10	73631-83D10	73631-83D10
3	94585640	94585640	94585640	94585640	94585640
4	94585640	94585640	94585640	94585640	94585640
5	94585640	94585640	94585640	94585640	94585640
6	94585640	94585640	94585640	94585640	94585640
REV. D/T	ECN NO	DATE	REASON	REWORK	REWORK