

**«UzAuto Motors» AJ**  
**TEXNIK TOPSHIRIQ**



22TT-9036-00120

2022-08-01

TEXNIK TOPSHIRIQ TT

Butlovchi qism nomi	96612058-BUSH,STABILIZER BAR 96612057-BUSH-STABILIZER BAR END
Texnik ko`rsatkichlari	96612058-BUSH,STABILIZER BAR AA614(EDS-M-7001) 96612057-BUSH-STABILIZER BAR END AA718(EDS-M-7001) <i>Umumiy texnik ko'rsatkichlar, butlovchi qismga qo'yiladigan talablar va o'lchamlar butlovchi qism chizmasida to'liq ko'rsatilgan.(chizmalar ilova qilinadi)</i>

Butlovchi  
qismga  
texnika-  
texnologik  
talablar

### **Mahsulotni qabul qilish**

Mahsulotni sifati bo'yicha qabul qilish buyurtmachining "Butlovchi qismlarni kiritish nazorati" standartiga asosan amalga oshiriladi.

Mahsulotni miqdor va sifat bo'yicha qabul qilish buyurtmachining korxonasida ta'minotchining vakili ishtirokida amalga oshiriladi.

Yetkazib berilgan mahsulot miqdori buyurtmachi tomonidan taqdim etilgan talabnomaga binoan, yozma yoki elektron shaklda kelishilgan shaklda berilgan hajmlarga mos kelishi lozim.

### **Mahsulot sifati**

Ta'minotchi buyurtmachiga mahsulotni buyurtmachi tomonidan joriy etilgan me'yor va o'rnatilgan standart, mahsulotni sifatini, chizmalar talablari, me'yoriy xujjatlar, nazorat qilish usullari asosida yetkazib berilishiga kafolat beradi.

Mahsulot materialini, tuzilishini yoki hujjatlarni bir tomonlama o'zgartirilishga yo'l qo'yilmaydi.

Buyurtmachi mahsulot sifatini va ta'minotchining ekologik sertifikatini mavjudligini tekshirish huquqiga ega va zarur hollarda bu tekshirish huquqi bevosita iste'molchiga ham berilishi mumkin.

### **Sifat kafolati.**

Agar mahsulot kam yetkazib berilishi va sifat nomuvofiqligi, qadoqsiz va o'ramasiz yoki talab darajasida bo'lmagan qadoqda va o'ramada kelganligi, markasiz yoki talab darajada markalanmaganligi ta'minotchi vakili ishtirokida aniqlansa, ta'minotchi 3 (uch) ish kunida ushbu kamchiliklarni bartaraf etishi va yetishmayotgan miqdorini o'z mablag'lari xisobidan to'ldirilishi lozim, shuningdek buyurtmachidan yozma xabar(pochta, faks, elektron pochta) qabul qilinganidan keyin yoki yetkazib berilgan sanadan boshlab 1 (bir) ish kuni ichida tegishli idishga qadoqlash, markalash ishlarini bajarishi kerak.

Butlovchi qismning ishlatilish joyi	Yig'uv sexida ishlatiladi
Narx qismi	Tender taklifida ko'rsatilgan narxlar eng past narxdan oshmasligi kerak va keyinchalik o'zgartirilishi mumkin emas. Taqdim qilingan narxlar O'zbekiston Respublikasi milliy valyutasi so'mda va qo'shimcha qiymat solig'i (QQS) bilan ko'rsatilishi lozim.
Fotosurat	Ilovada ko'rsatilgan.
Chizmasi va umumiy talablar	Ilovada ko'rsatilgan.
Qo'shimcha talablar	<p style="text-align: center;"><b>Tara va Qadoqlash</b></p> <p>Butlovchi qismni yetkazib berishda shakli va hajmi ta'minotchi tomonidan ishlab chiqilgan va buyurtmachi bilan kelishilgan maxsus idishlar ishlatiladi va buyurtmachi bilan kelishilgan talablarga ko'ra markalanishi lozim.</p> <p>Mahsulotni yetkazib berishda quyidagi ma'lumotlarni o'z ichiga olgan yorliq yopishtiriladi.</p> <ul style="list-style-type: none"> <li>– avtomobil turi;</li> <li>– butlovchi qism nomi, raqami va soni;</li> <li>– ta'minotchining kodi;</li> <li>– yetkazib berish joyi;</li> <li>– idish hajmi, qadoqlash sanasi, nazorat xolati va boshqalar.</li> </ul>

**Tasdiq**

**Boshqaruvchi direktor**



2022-08-01 16:25

**S. M.  
Jumaniyazov**  
2022-08-01 11:50

**Rozilik**

**Boshqarma boshlig'i**  
*Global xarid qilish va ta'minot tizimi  
boshqarmasi*



2022-08-01 11:50

**U. P. Ruzibayev**  
2022-07-27 10:22

**Bo'lim boshlig'i**  
*Global xarid bo'limi*



2022-08-01 10:53

**D. K. Annaqov**  
2022-07-27 10:22

**Bo'linma boshlig'i**  
*HVAC, shassi va uzellar bo'linmasi*



2022-07-27 17:01

**E. I. Qilichov**  
2022-07-27 10:22

**Mas'ul**

---

**Muhandis-texnolog**  
*HVAC, shassi va uzellar bo'linmasi*



2022-07-27 10:22

**B. U. Raximov**  
2022-07-27 10:22

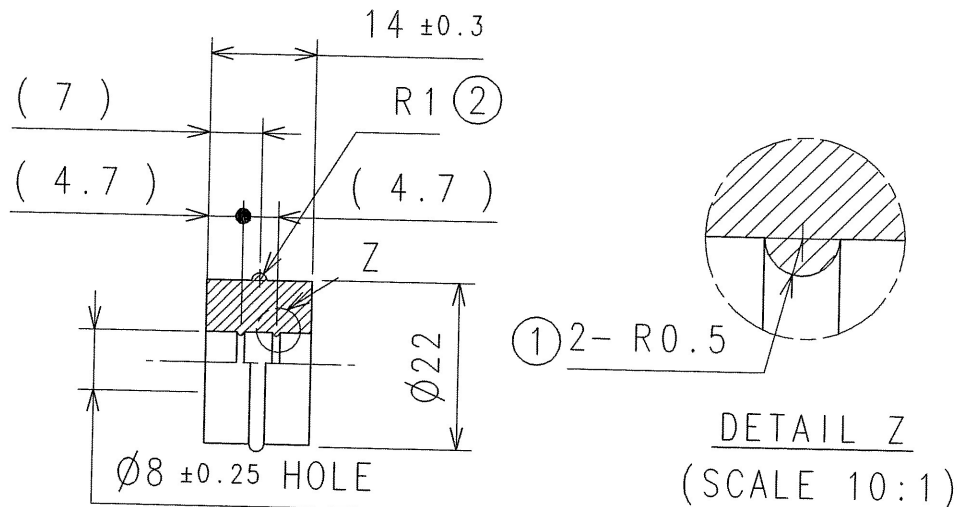

DETAIL Z  
(SCALE 10:1)

- OZONE RESISTANCE TEST (EDS-T-7405)
- BE FREE FROM CRACKS UNDER THE FOLLOWING CONDITION
  - OZONE DENSITY : 50pphm
  - TEMPERATURE : 40±3°C
  - TOTAL TENSION : 20%
  - TEST TIME : 48hours
- RUBBER HARDNESS : HS = 60±5 (MATERIAL).
- TENSILE STRENGTH : 145kg/cm<sup>2</sup> MIN.
- ELONGATION : 430% MIN.
- UNSPECIFIED CORNER RADIUS : R MIN.
- RESTRICTED AND REPORTABLE SUBSTANCES FOR PARTS
- ③ PER GMW3059.
  - 부품의 구성 성분은 GMW3059에 따라 금지 또는 신고되어야 한다.

COMPUTER GRAPHICS CHANGE RESTRICTED NO MANUAL CHANGES

DATE	SYM	REVISION RECORD	AUTHORITY	DS	CK	AP
3 1A U0 7	3	NOTE ADDED.	PCD0016D1	DW	DW	CS
0 2J L0 3	2	ADDED RIB.	CT3-0142D	SS	CS	MG
1 9J N0 3	1	ADDED RIB.	CT3-0121D	SS	CS	MG
0 6MR 0 3	-	PRODUCTION RELEASE	CT3-0024D	SS	CS	MG

PROPERTY OF GM DAEWOO AUTO&TECHNOLOGY. (COPYRIGHT). THIS DRAWING MUST NOT BE REPRODUCED OR DISCLOSED TO THIRD PARTIES WITHOUT THE PRIOR CONSENT OF GM DAEWOO AUTO&TECHNOLOGY. ALL RIGHT RESERVED.  
본 도면은 지엠대우오토엔지니어링(주)의 재산임 (판권). 본 도면은 지엠대우오토엔지니어링(주) 사전 승인없이 복사하거나 제3자에게 공개 할수없으며, 모든권한은 당사가 보유하고 있음

DIMENSIONS ARE IN MILLIMETERS. ALLOWABLE VARIATION ON ALL 치수는 mm 임. 보통 치수 허용차  
DIMENSIONS ARE ± 0.5 UNLESS OTHERWISE SPECIFIED 임.

PROJ NO.	DWG DATE	SCALE	DSGN	CHK	APR
B150	06, MR, 03	1 : 1	황성식	오창식	김문곤

MATERIAL AA614(EDS-M-7001)	WEI- GHT	EST 6.5g
	ACT -	

도 명 부시-스태이בל라이저 바 엔드  
NAME BUSH-STAB BAR END

DRAWING NO.	SIZE
96 612 057	A4

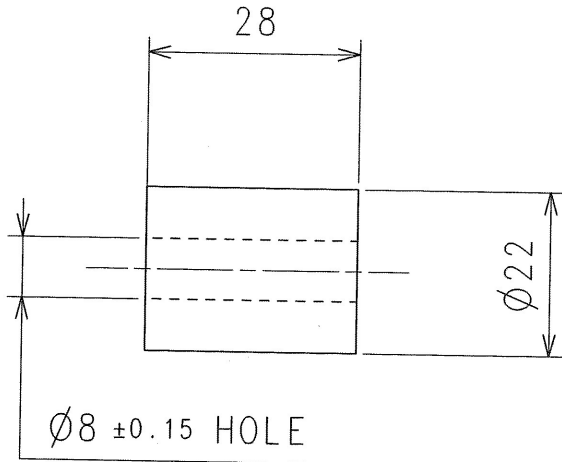

- DYNAMIC PROPERTIES : JIS K 6394 TYPE N2  
Kd/Ks(100Hz, AMPLITUDE ±0.05mm) : 2.7 MAX  
TANδ 15Hz(AMPLITUDE ±15mm) : 0.14 MIN
- OZONE RESISTANCE TEST (EDS-T-7405)  
BE FREE FROM CRACKS UNDER THE FOLLOWING CONDITION
  - OZONE DENSITY : 50pphm
  - TEMPERATURE : 40±3°C
  - TOTAL TENSION : 20%
  - TEST TIME : 72hours
- RUBBER HARDNESS : HS = 70±5 (MATERIAL).
- UNSPECIFIED CORNER RADIUS : R0.2-R0.3
- RESTRICTED AND REPORTABLE SUBSTANCES FOR PARTS
  - ① PER GMW3059.
  - 부품의 구성 성분은 GMW3059에 따라 금지 또는 신고되어야 한다.

COMPUTER GRAPHICS

CHANGE RESTRICTED NO MANUAL CHANGES

31AU071	1	NOTE ADDED.		PCD0016D1	DW	DW	CS		
06MR03	-	PRODUCTION RELEASE		CT3-0024D	SS	CS	MG		
DATE	SYM	REVISION RECORD		AUTHORITY	DS	CK	AP		
PROPERTY OF GM DAEWOO AUTO&TECHNOLOGY. (COPYRIGHT). THIS DRAWING MUST NOT BE REPRODUCED OR DISCLOSED TO THIRD PARTIES WITHOUT THE PRIOR CONSENT OF GM DAEWOO AUTO&TECHNOLOGY. ALL RIGHT RESERVED. 본 도면은 지엠대우오토엔테크놀로지(주)의 재산임(판권). 본 도면은 지엠대우오토엔테크놀로지(주) 사전 승인없이 복사하거나 제3자에게 공개 할수없으며, 모든권한은 당사기 보유하고 있음									
		DIMENSIONS ARE IN MILLIMETERS. ALLOWABLE VARIATION ON ALL 치수는 mm 임. 보통 치수 허용차 DIMENSIONS ARE ± 0.5 UNLESS OTHERWISE SPECIFIED 는 임.							
PROJ NO.	DWG DATE	SCALE	DSGN	CHK	APR				
B150	06, MR, 03	1 : 1	황성식	오창식	김문곤				
		MATERIAL			WEI-GHT	EST 0.0g			
		AA718(EDS-M-7001)			ACT	-			
도 명 부시-스태이בל라이저 바 센터 NAME BUSH-STAB BAR CENTER									
DRAWING NO.							SIZE		
96 612 058							A4		