

«UzAuto Motors» AJ
TEXNIK TOPSHIRIQ



22TT-9036-00132

2022-08-15

TEXNIK TOPSHIRIQ TT

Butlovchi qism nomi	96915458- BRACKET SUNV
	96915525 - BRACKET BRAKE
	96915526 - BRACKET FRONT
	96915527 - BRACKET HEAT
Texnik ko`rsatkichlari	Material: SPCC - 1.2
	SPCC - 1.4

<p>Butlovchi qismga texnika-texnologik talablar</p>	<p style="text-align: center;">Mahsulotni qabul qilish</p> <p>Masulotni sifati bo`yicha qabul qilish buyurtmachining “Butlovchi qismlarni kiritish nazorati” standartiga asosan amalga oshiriladi.</p> <p>Mahsulotni miqdor va sifat bo`yicha qabul qilish buyurtmachining korxonasida ta`minotchining vakili ishtirokida amalga oshiriladi.</p> <p>Yetkazib berilgan mahsulot miqdori buyurtmachi tomonidan taqdim etilgan talabnomaga binoan, yozma yoki elektron shaklda kelishilgan shaklda berilgan hajmlarga mos kelishi lozim.</p> <p style="text-align: center;">Mahsulot sifati</p> <p>Ta`minotchi buyurtmachiga mahsulotni buyurtmachi tomonidan joriy etilgan me`yor va o`rnatilgan standart, mahsulotni sifatini, chizmalar talablari, me`yoriy xujjatlar, nazorat qilish usullari asosida yetkazib berilishiga kafolat beradi.</p> <p>Mahsulot materialini, tuzilishini yoki hujjatlarni bir tomonlama o`zgartirishga yo`l qo`yilmaydi.</p> <p>Buyurtmachi mahsulot sifatini va ta`minotchining ekologik sertifikatini mavjudligini tekshirish huquqiga ega va zarur hollarda bu tekshirish huquqi bevosita iste`molchiga ham berilishi mumkin.</p> <p style="text-align: center;">Sifat kafolati.</p> <p>Agar mahsulot kam yetkazib berilishi va sifat nomuvofiqligi, qadoqsiz va o`ramasiz yoki talab darajasida bo`lmagan qadoqda va o`ramada kelganligi, markasiz yoki talab darajada markalanmaganligi ta`minotchi vakili ishtirokida aniqlansa, ta`minotchi 3 (uch) ish kunida ushbu kamchiliklarni bartaraf etishi va yetishmayotgan miqdorini o`z mablag`lari xisobidan to`ldirilishi lozim, shuningdek buyurtmachidan yozma xabar(pochta, faks, elektron pochta) qabul qilinganidan keyin yoki yetkazib berilgan sanadan boshlab 1 (bir) ish kuni ichida tegishli idishga qadoqlash, markalash ishlarini bajarishi kerak.</p>
<p>Butlovchi qismning ishlatilish joyi</p>	<p>Payvandlash tsexida ishlatiladi</p>

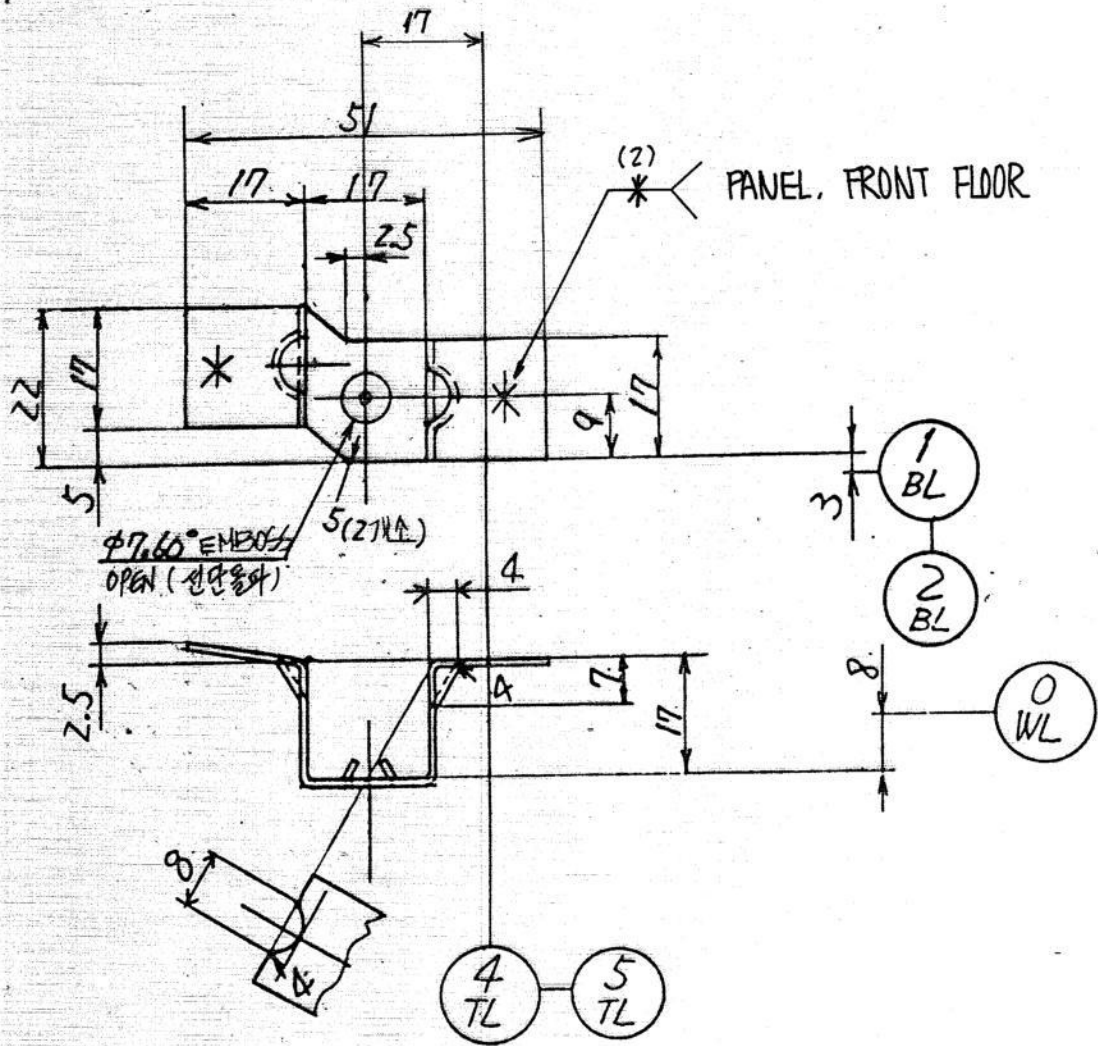

- 주기
- 본 부품은 내측에 부착함
 - 재미없는 R은 R2로 한다.

NOTE

- THIS PART IS ONLY INSTALLED ON LH
- UNSPECIFIED R : R2

NOTE

-RESTRICTED AND REPORTABLE SUBSTANCES FOR PARTS PER GMW3059.

-부품의 구성 성분은 GMW 3059에 따라 금지 또는 신고되어야 한다.

PART NAME		△					
BRACKET, HEATER HOSE		△					
PART NUMBER		△					
△ 94 584 389		△	1	PCB0025D1	ADDED NOTE	31. Au. 07	서영자
		△	1	BT3-0001D	WAS P/NO. 61119-85200	10. FE. 03	서영자
		△		BT2-0302	RE-DRAW'G	92.12.31	우형
REF. DWG.	REV. Q'TY	ECN. NO.	CONTENTS		DATE	RVD'BY	
MATERIAL (SCRAP MAY BE USED)	HEAT TREATMENT	SURFACE FINISHING		SCALE	PAGE		
SPLC-NS ±1.0~±1.2				1:1	1/1		
DWG. BY	CHECKED BY	APPRD BY	APPRD BY				
김수현	원정희	김수현	원정희				
기종: YTT11.51	BLK: CL200	WT: 10g	SZ: A4				



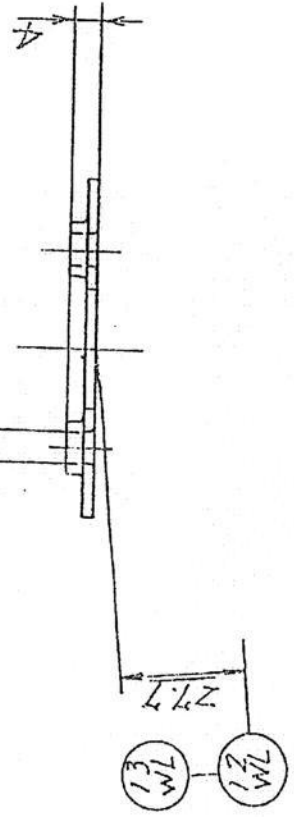
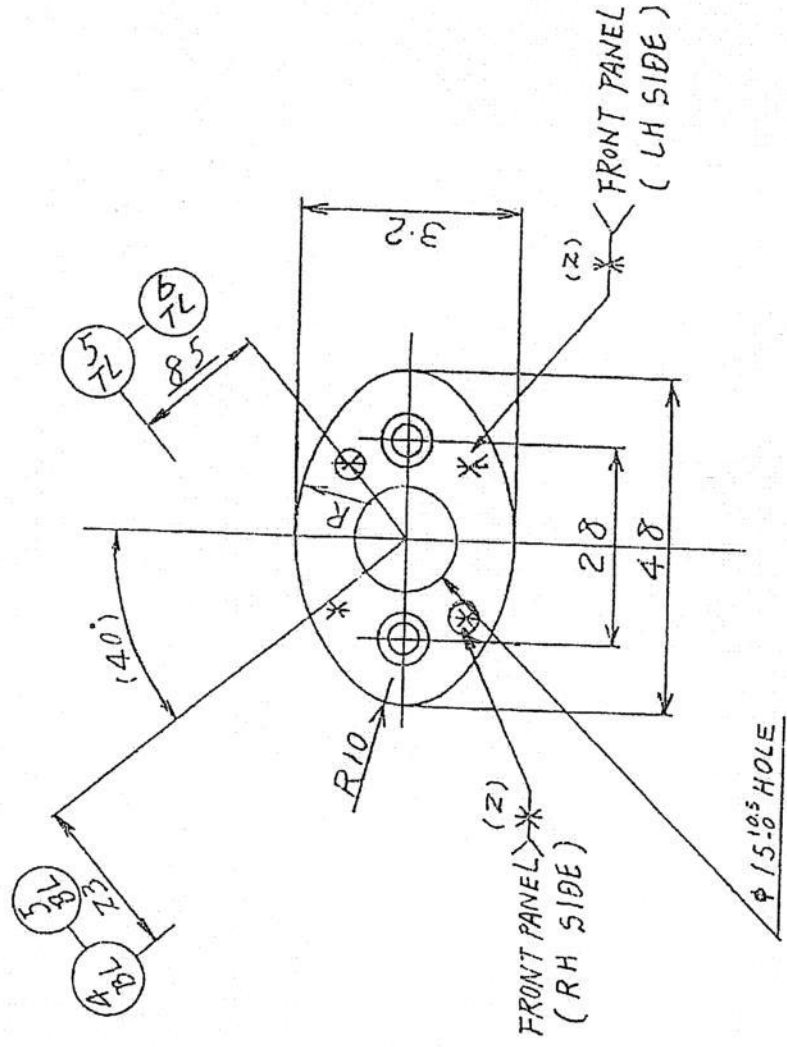

NOTE:

- ASSEMBLED CONDITION ON RH SIDE SHOWN, SYMM ON LH SIDE.

PART NUMBER 96 915 458		PART NAME BRACKET, SUNVISOR		GEN. TOL. EDS-A-1101	
REF. DWG 96915458		DSND BY <i>[Signature]</i>	CHKD BY <i>[Signature]</i>	APPVD BY <i>[Signature]</i>	APPVD BY <i>[Signature]</i>
MATERIAL SPHC or SPCC (th:1.4)		SURFACE FINISHING — / —		DATE: 2013 . 09 . 05 .	
HEAT TREATMENT — / —		SCALE N : S		PAGE 1/1	
MODEL: V7T11		BLOCK: CL 100		ЗАО "ДжиЭм Узбекистан"	

ITEM	PART NO.	PART NAME	Q'TY	MATERIAL	REMARKS
Ⓐ					

REV	Q'TY	ECN NO.	DATE	CONTENTS	RVD BY	CHKD BY	APPVD BY
2			09.13	DRAWING RELEASE			
1		13200010	03.02.10				

CL200

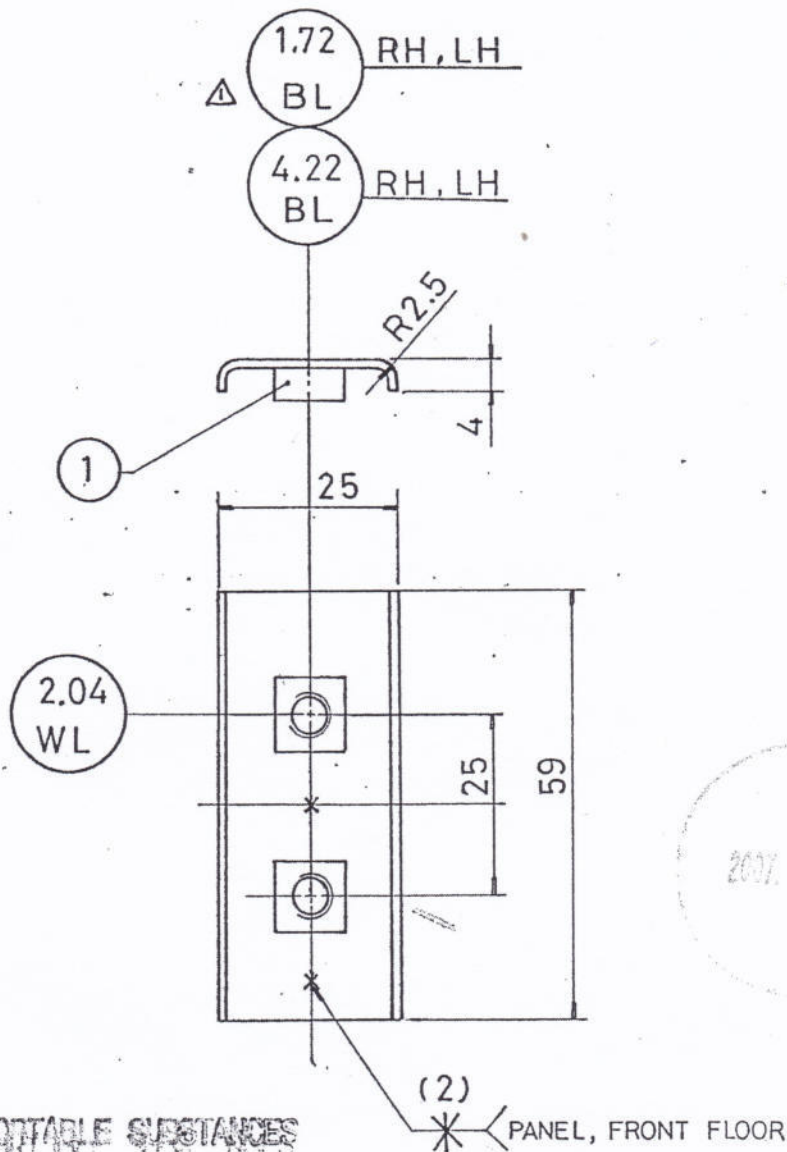

NOTE Δ

-RESTRICTED AND REPORTABLE SUBSTANCES FOR PARTS PER OMI/ROD.

이 품의 구성 성분은 GHS 09/10에 따라 신고되어야 한다.

1	Δ 94.515 079	NUT, FRONT SEAT	2		
ITEM	PART NO.	PART NAME	Q'TY	MATERIAL	REMARKS Δ

PART NAME		Δ				
BRACKET, FRONT SEAT		Δ	1	PCB00 25 ϕ 1	ADDED NOTE	31.AU.07 서영재
PART NUMBER		Δ	2	BT2-00010	WAS P/NO.08215-11069	10.FE.03 서영재
94 584 388		Δ			WAS P/NO.61118AE5000	
		Δ	0	BT2-0302	열문주기 추가	92.12.31 하형총
		Δ	1	BT2-0153	회복 위치 추가 (172BL)	92.5.22 하형총
				BT0-0439	REDESIGN	90.12.19 하형총
REF. DWG.	61110 - 80D0	REV.	Q'TY	ECN. NO.	CONTENTS	DATE RVD'BY

MATERIAL t1.2		HEAT TREATMENT		SURFACE FINISHING		SCALE	PAGE
SPCC-NS OR SPHC						1 : 1	1 / 1
DWG. BY	CHECKED BY	APPRD BY	APPRD BY				
하형총	안영희						
DATE	1990 . 12 . 19						

대우조선공업주식회사
DAEWOO SHIPBUILDING & HEAVY MACHINERY LTD.

Narx qismi	Tender taklifida ko`rsatilgan narxlar eng past narxdan oshmasligi kerak va keyinchalik o`zgartirilishi mumkin emas. Taqdim qilingan narxlar O`zbekiston Respublikasi milliy valyutasi so`mda va qo`shimcha qiymat solig`i (QQS) bilan ko`rsatilishi lozim.
Fotosurat	Ilovada ko'rsatilgan.
Chizmasi va umumiy talablar	Ilovada ko'rsatilgan.

<p>Qo`shimcha talablar</p>	<p style="text-align: center;">Tara va Qadoqalash</p> <p>Butlovchi qismni yetkazib berishda shakli va hajmi ta`minotchi tomonidan ishlab chiqilgan va buyurtmachi bilan kelishilgan maxsus idishlar ishlatiladi va buyurtmachi bilan kelishilgan talablarga ko`ra markalanishi lozim.</p> <p>Mahsulotni yetkazib berishda quyidagi ma`lumotlarni o`z ichiga olgan yorliq yopishtiriladi.</p> <ul style="list-style-type: none"> – avtomobil turi; – butlovchi qism nomi, raqami va soni; – ta`minotchining kodi; – yetkazib berish joyi; – idish hajmi, qadoqlash sanasi, nazorat xolati va boshqalar. <p>Butlovchi qismni yetkazib berishda shakli va hajmi ta`minotchi tomonidan ishlab chiqilgan va buyurtmachi bilan kelishilgan maxsus idishlar ishlatiladi va buyurtmachi bilan kelishilgan talablarga ko`ra markalanishi lozim.</p> <p>Mahsulotni yetkazib berishda quyidagi ma`lumotlarni o`z ichiga olgan yorliq yopishtiriladi.</p> <ul style="list-style-type: none"> – avtomobil turi; – butlovchi qism nomi, raqami va soni; – ta`minotchining kodi; – yetkazib berish joyi; – idish hajmi, qadoqlash sanasi, nazorat xolati va boshqalar.
----------------------------	--

Tasdiq

Boshqaruvchi direktor



2022-08-15 16:51

**S. M.
Jumaniyazov**
2022-08-15 14:55

Rozilik

Boshqarma boshlig'i

*Global xarid qilish va ta'minot tizimi
boshqarmasi*



2022-08-15 14:55

U. P. Ruzibayev

2022-08-15 11:08

Bo'lim boshlig'i

Maxallillashtirish bo'limi



2022-08-15 14:35

D. K. Annaqov

2022-08-15 11:08

Bo'linma boshlig'i

*Interior, Exterior va kuzov qismlari
bo'linmasi*



2022-08-15 13:06

G. A. Saidov

2022-08-15 11:08

Mas'ul

Muhandis-texnolog

*Interior, Exterior va kuzov qismlari
bo'linmasi*



2022-08-15 11:08

B. R.

Qutlimuratov

2022-08-15 11:08